

# KAPPA-15/GR

## *Diaphragm Pump with Gear Reduction*

The **KAPPA-15/GR** is an internally manifolded, two-diaphragm pump of anodized aluminum construction.

The **KAPPA-15/GR** comes with a pulsation dampener, adjustable pressure regulator, and gear reduction for a 3 & 3 1/2 HP gasoline engine.



Also available is a model equipped with a 5/8" engine shaft designed to fit 2.2 & 2.5 HP Honda engines. For this model, order part number - **KAPPA-15/GR-5/8**

### **SPECIFICATIONS**

Maximum Flow .....	3.2 GPM
Maximum Pressure .....	250 PSI
Hose Barb Ports	
In .....	3/4"
Out .....	3/8"
Bypass .....	5/8"
Dimensions .....	L-10.5" x W-7" x H-7"
Weight .....	10 lbs.
Diaphragm Material	
Standard .....	DESMOPAN
Optional .....	BUNA-N

NOTE - Protect pumps from freezing. If freezing conditions exist, flush pump and system with a 50/50 mixture of anti-freeze and water.

### **UDOR U.S.A., INC.**

500 Apollo Drive  
Lino Lakes, MN 55014  
TEL. (651) 785-0666  
FAX. (800) 732-2670  
[www.udorusa.com](http://www.udorusa.com)



# KAPPA-15/GR - Exploded View Diagram and Parts List

## KAPPA-15 PUMP

Requires 4 oz.  
**UDOR LUBE,**  
or SAE 40W  
Non-detergent Oil

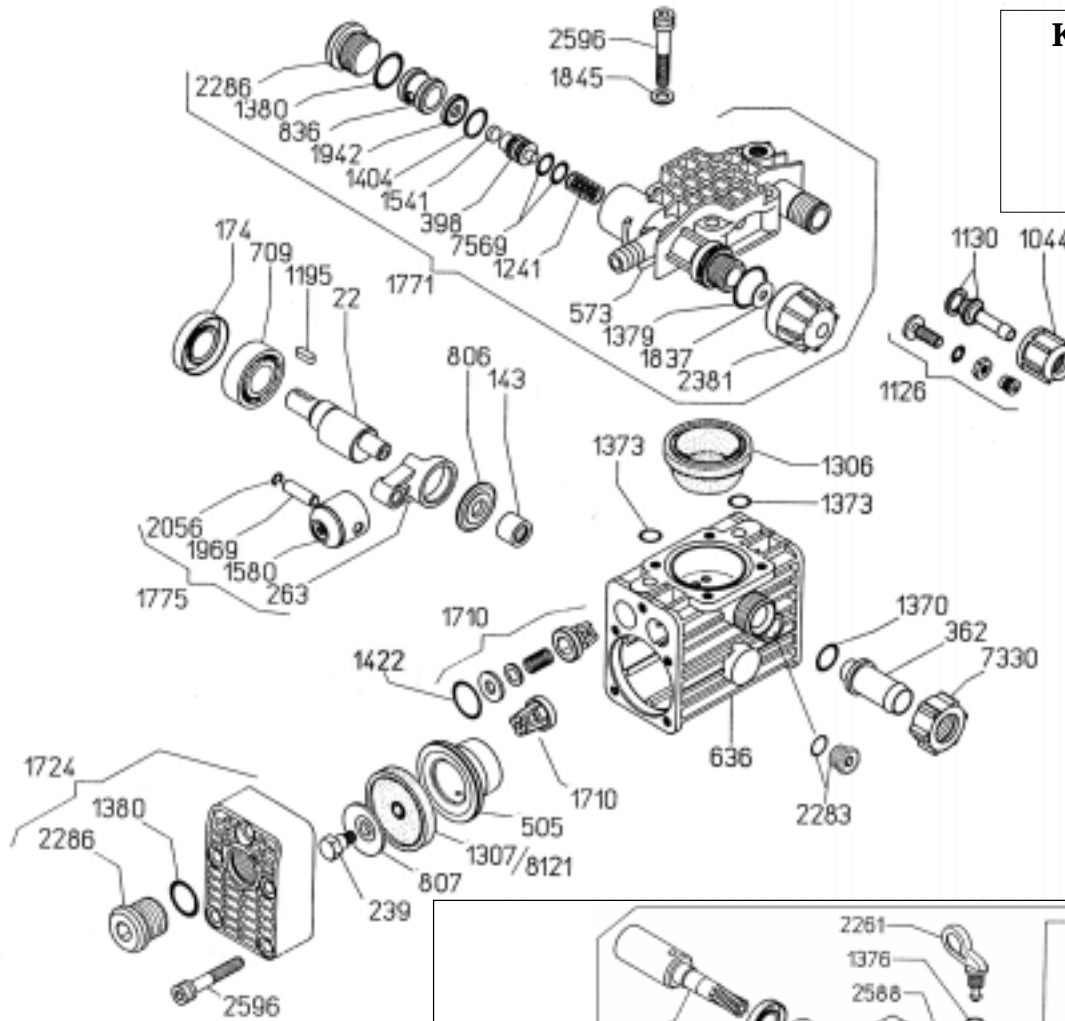

Ref. #	Part #	Qty.	Description
22	0002.75	1	Crankshaft - KAPPA-15
113	0004.19	1	Gearshaft - 3/4"
117	0004.24	1	Gearshaft - 5/8"
143	0006.33	1	Bearing
166	0007.21	1	Seal
174	0007.37	1	Seal
239	0102.02	2	Diaphragm Bolt
263	0103.07	2	Connecting Rod
362	0202.27	1	Suction Hose Barb
◇398	0203.10	1	R.V. Piston
505	0206.33	2	Piston Sleeve - KAPPA-15
573	0208.47	1	Discharge Manifold
636	0209.48	1	Pump Body
685	0213.32	1	Pump Gear
703	0214.08	1	Bearing
709	0214.17	1	Bearing
754	0228.34	1	Mounting Flange
806	0301.35	1	Spacer
807	0301.37	2	Diaphragm Washer
◇836	0302.57	1	R.V. Spacer
870	0304.02	4	Lock Nut
1044	0604.30	1	Barb Nut
1126	0608.16	1	Air Valve Assembly
1130	0202.09	1	Hose Barb - 3/8"
1195	0801.08	1	Shaft Key
1241	0901.52	1	R.V. Spring
*1306	0903.44	1	Accumulator Diaphragm
1307	0903.45	2	Piston Diaphragm (BUNA-N)
1349	GG-0350	1	Pressure Gauge (Optional)
1370	1101.06	1	O-Ring
*1373	1101.11	2	O-Ring

## GEARBOX

Requires 2 oz.  
SAE 80W90  
Gear Lube

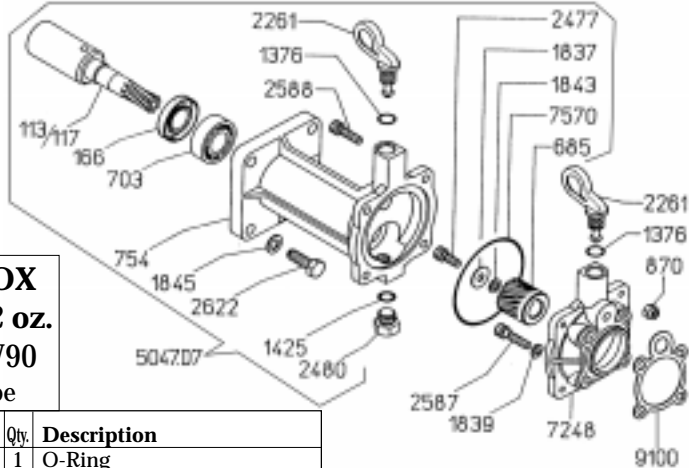

Ref. #	Part #	Qty.	Description
1376	1101.16	1	O-Ring
◇1379	1101.23	1	O-Ring
1380	1101.25	3	O-Ring
1404	1101.61	1	O-Ring
1422	1101.78	4	O-Ring
1425	1101.76	1	O-Ring
◇1541	1204.15	1	IOTA R.V. Collar
1580	1205.27	2	Piston
1710	6006.11	4	Valve Assembly
1724	6017.14	2	Pump Head
1771	6005.26	1	Discharge Manifold Ass'y
1775	6015.31	2	Piston Rod Assembly
1837	1403.29	2	Washer
1839	1403.27	4	Washer
1843	1403.07	1	Washer
1845	1403.10	8	Washer
◇1942	1501.33	1	Seat
1969	1502.11	2	Wrist Pin
2056	1506.24	2	Snap Ring
2261	1603.23	2	Oil Plug

\*When ordering Gearbox #5047.D7, please specify 5/8" or 3/4" shaft size.

Ref. #	Part #	Qty.	Description
2283	1603.69	1	Oil Indicator Sight Glass
2286	1603.87	3	Plug
2381	1801.21	1	R.V. Cap
2477	1804.67	1	Bolt, M6 x 16
2480	1603.14	1	1/4" Gas Brass Plug
2587	1805.20	4	Bolt
2588	1805.21	4	Bolt, M6 x 22
2596	1805.23	14	Bolt, M8 x 40
2622	1807.07	4	Bolt, 5/16" x 1"
7248	0501.88	1	Gear Case
7330	0604.29	1	Barb Nut
◇7569	1101.54	2	O-Ring
7570	1101.91	1	O-Ring
*8121	0903.49	2	Piston Diaphragm (DESMOPAN)
9100	0602.49	1	Gasket

\* Parts included in Diaphragm Repair Kit, Part # 8700.27. Also available in BUNA-N, Part # 8700.28

◇ Parts included in Control Unit Repair Kit, Part # 8701.05