

KAPPA-30/40

Medium Pressure Diaphragm Pump

KAPPA-30 & KAPPA-40 medium pressure, 2-cylinder diaphragm pumps are excellent choices for various horticulture, agricultural, lawn care, pest control and turf spraying applications. They are also effectively used in other applications such as aircraft de-icing, hydrostatic testing and cleaning.

KAPPA-30 & KAPPA-40 pumps are constructed of anodized aluminum with anodized aluminum and stainless steel liquid handling parts. Built-in pulsation dampener, control valve and pressure gauge are standard on all models.



Drive options include:

- 5027.75 4-6.5 HP Gear Reduction
- 7702.01 1-3/8", 6-spline male PTO shaft, base, bolts & safety shield.
- 7751.A1 1" solid keyed shaft, base & bolts.
- 7752.A2 1-3/8" 6-spline female PTO adapter & bolts, torque arms, chains & safety shield.

For applications not listed, please consult UDOR U.S.A.

SPECIFICATIONS

Maximum Flow	
KAPPA-30	8.5 GPM
KAPPA-40	10.5 GPM
Maximum Pressure	560 PSI
Maximum RPM.....	540 RPM
Maximum Temperature	140°F
Inlet Port - Hose Barb.....	1"
Outlet Ports - Hose Barb (Ball Valve Controlled)	1/2" (2)
Bypass - Hose Barb	3/4"
Dimensions	L-10.5" x W-11" x H-13"
Weight	28 lbs.
Diaphragm Material	
Standard.....	DESMOPAN
Optional	BUNA-N

NOTE - Protect pumps from freezing. If freezing conditions exist, flush pump and system with a 50/50 mixture of anti-freeze and water.

UDOR U.S.A., INC.

500 Apollo Drive
Lino Lakes, MN 55014
TEL. (651) 785-0666
FAX. (800) 732-2670

www.udorusa.com

KAPPA-30/40 - Exploded View Diagram and Parts List

KAPPA-30/40 PUMPS

Require 20 oz.
UDOR LUBE
or SAE 40W
Non-detergent Oil

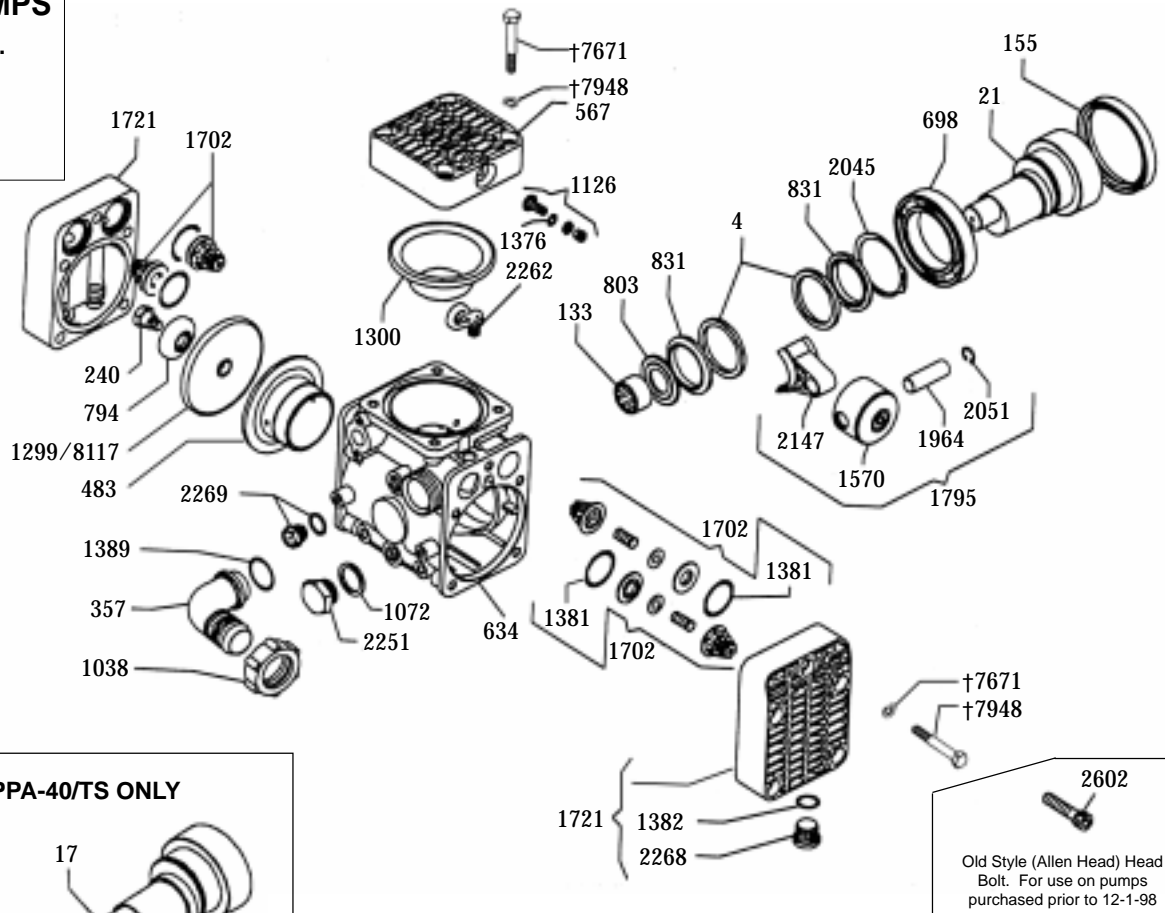

FOR KAPPA-40/TS ONLY

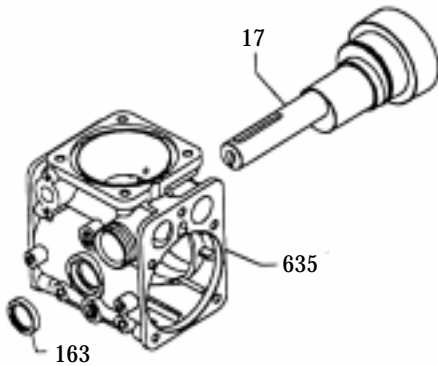

FOR KAPPA-50 ONLY

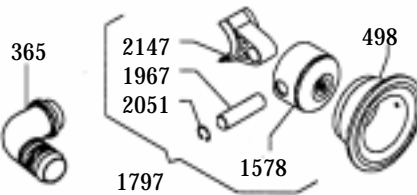

FOR KAPPA-30 ONLY

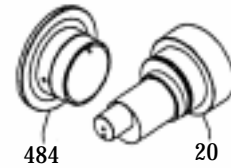

REF#	PART#	DESCRIPTION	QTY	REF#	PART#	DESCRIPTION	QTY
4	0001.06	Retaining Ring	2	1382	1101.29	O-Ring	4
***17	0002.72	KAPPA 40/50 Crankshaft (T.S.)	1	1389	1101.41	O-Ring	1
20	0002.70	KAPPA-30 Crankshaft	1	1570	1205.07	Piston - KAPPA-30/40	2
21	0002.71	KAPPA-40/50 Crankshaft	1	**1578	1205.18	Piston - KAPPA-50	2
133	0006.02	Bearing	1	1702	6006.01	Valve Assembly	4
155	0007.01	Seal	1	1721	6017.06	Head Assembly	2
***163	0007.19	Seal	1	1795	6015.21	Piston/Rod Assembly - KAPPA-30/40	2
240	0102.04	Diaphragm Bolt	2	**1797	6015.23	Piston/Rod Assembly - KAPPA-50	2
357	0202.18	Inlet Hose Barb (KAPPA-30/40)	1	1964	1502.03	Connecting Rod Pin - KAPPA-30/40	2
**365	0202.52	KAPPA-50 Inlet Hose Barb	1	**1967	1502.07	Connecting Rod Pin - KAPPA-50	2
483	0206.08	KAPPA-40 Piston Sleeve	2	2045	1506.01	Snap Ring	1
484	0206.09	KAPPA-30 Piston Sleeve	2	2051	1506.15	Snap Ring	4
**498	0206.25	KAPPA-50 Piston Sleeve	2	2147	1519.14	Connecting Rod (KAPPA-30/40/50)	2
567	0208.34	Accumulator Head	1	2251	1603.02	Plug	1
634	0209.40	Pump Body (KAPPA-30/40/50)	1	2262	1603.24	Oil Plug	1
***635	0209.41	Pump Body (T.S.)	1	2268	1603.32	Head Plug	4
698	0214.01	Ball Bearing	1	2269	1603.33	Oil Sight Glass	1
794	0301.14	Retainer Washer	2	2602	1805.25	Head Bolt (Allen Head - Old Style)	14
803	0301.30	Washer	1	†7671	1403.09	Washer (Use with Ref #7948 Only)	14
831	0302.50	Spacer	2	†7948	1804.45	Head Bolt (Hex Head - New Style)	14
1038	0604.18	Suction Nut	1	*8117	0903.38	Piston Diaphragm (DESMOPAN)	2
1072	0605.09	Gasket	1				
1126	0608.16	Air Valve Assembly	1				
1299	0903.13	Piston Diaphragm (BUNA-N)	2				
*1300	0903.14	Accumulator Diaphragm	1				
1376	1101.16	O-Ring	1				
*1381	1101.27	O-Ring	4				

* Parts included in Diaphragm Repair Kit - Part #8700.02
Diaphragm Repair Kit also available in BUNA-N - Part #8700.12

** Parts for KAPPA-50 Only.

*** Parts for KAPPA-40/TS Only.

† For use with new style heads and pulsation dampener purchased after 12-1-98.