

KAPPA-35/55

Medium Pressure Diaphragm Pumps

KAPPA-35/55 3-cylinder, medium pressure diaphragm pumps are excellent choices for various horticulture, agricultural, lawn care, nursery, pest control and turf spraying applications. They are also effectively used in other applications such as aircraft de-icing, hydrostatic testing and cleaning.

KAPPA-35/55 pumps are constructed of anodized aluminum with anodized aluminum and stainless steel liquid handling parts. Built-in pulsation dampener, control valve and pressure gauge are standard on all models.

Drive options include:

Part Number	Description
4155.00	Hydraulic Motor Mounting Kit.
5027.75	4 - 6.5 HP Gear Reduction.
5033.A4	8-13 HP Gear Reduction.
7751.A3	1" solid keyed shaft.
7752.A2	1-3/8" 6-spline female PTO adapter & bolts, torque arms, chains & safety shield.
7753.A6*	1-3/8", 6-spline male PTO shaft.

* For ALL PTO drive applications, Safety Shield #1219.02 (ordered separately) MUST be used.

For applications not listed, please consult UDOR U.S.A.



SPECIFICATIONS

Maximum Flow	
KAPPA-35	10.5 GPM
KAPPA-55	15 GPM
Maximum Pressure	560 PSI
Maximum RPM.....	540 RPM
Maximum Temperature	140°F
Inlet Port - Hose Barb	
KAPPA-35	1"
KAPPA-55	1-1/4"
Outlet Ports - Hose Barb (Ball Valve Controlled)	1/2" (2)
Bypass - Hose Barb	3/4"
Dimensions	L-11.5" x W-12.5" x H-10"
Weight	37 lbs.
Diaphragm Material	
Standard.....	DESMOPAN
Optional	BUNA-N

NOTE - Protect pumps from freezing. If freezing conditions exist, flush pump and system with a 50/50 mixture of anti-freeze and water.

UDOR U.S.A., INC.

500 Apollo Drive
Lino Lakes, MN 55014
TEL. (651) 785-0666
FAX. (800) 732-2670

KAPPA-35/55 - Exploded View Diagram and Parts List

Old Style (Allen Head) Head Bolt. For use on pumps purchased prior to 12-1-98

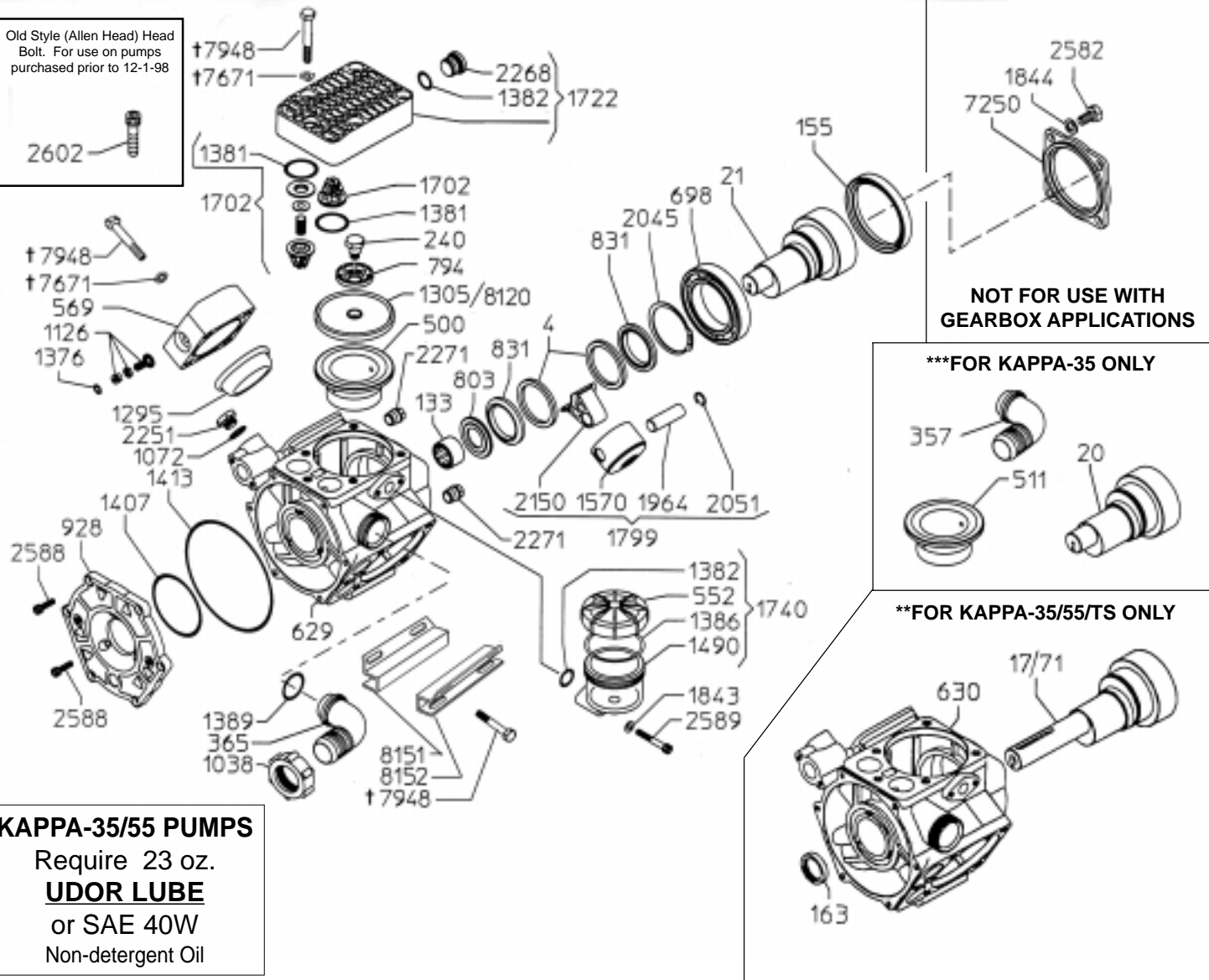

KAPPA-35/55 PUMPS
 Require 23 oz.
UDOR LUBE
 or SAE 40W
 Non-detergent Oil

REF#	PART#	DESCRIPTION	QTY	REF#	PART#	DESCRIPTION	QTY
4	0001.06	Retaining Ring	2	1413	1101.87	O-Ring	1
**17	0002.72	Crankshaft (KAPPA-55/TS)	1	1490	1203.27	Oil Reservoir	1
***20	0002.70	Crankshaft (KAPPA-35)	1	1570	1205.07	Piston	3
21	0002.71	Crankshaft (KAPPA-55)	1	1702	6006.01	Valve Assembly	6
**71	0002.A3	Crankshaft (KAPPA-35/TS)	1	1722	6017.13	Head Assembly	3
133	0006.02	Bearing	1	1740	6033.01	Oil Reservoir Assembly	1
155	0007.01	Seal	1	1799	6015.27	Piston/Rod Assembly	3
**163	0007.19	Seal (T.S.)	1	1843	1403.07	Washer	2
240	0102.04	Diaphragm Bolt	3	1844	1403.09	Washer	4
***357	0202.18	Suction Elbow (KAPPA-35)	1	1964	1502.03	Connecting Rod Pin	3
365	0202.52	Suction Elbow	1	2045	1506.01	Snap Ring	1
500	0206.31	Piston Sleeve (KAPPA-55)	3	2051	1506.15	Snap Ring	6
***511	0206.39	Piston Sleeve (KAPPA-35)	3	2150	1519.18	Connecting Rod	3
552	0208.07	Oil Reservoir Cap	1	2251	1603.02	Plug	1
569	0208.46	Accumulator Head	1	2268	1603.32	KAPPA Head Plug	6
629	0209.44	Pump Body	1	2271	1603.44	3/8" Plug	2
**630	0209.46	Pump Body (T.S.)	1	2582	1805.04	Bolt - M10x20	4
698	0214.01	Ball Bearing	1	2588	1805.21	Bolt - M6x22	9
794	0301.14	Retainer Washer	3	2589	1805.26	Bolt - M6x45	2
803	0301.30	Spacer	1	2602	1805.25	Head Bolt (Allen Head - Old Style)	19
831	0302.50	Spacer	2	7250	0501.02	Seal Retainer	1
928	0501.85	Body Flange	1	†7671	1403.09	Washer (Use with Ref #7948 Only)	15
1038	0604.18	Barb Nut	1	†7948	1804.45	Head Bolt (Hex Head - New Style)	19
1072	0605.09	Aluminum Gasket	1	*8120	0903.50	Piston Diaphragm (DESMOPAN)	3
1126	0608.16	Air Valve Assembly	1	8151	1202.63	Mounting Rail - Right Side	1
*1295	0903.08	Accumulator Diaphragm	1	8152	1202.64	Mounting Rail - Left Side	1
1305	0903.43	Piston Diaphragm (BUNA-N)	3				
1376	1101.16	O-Ring	1				
*1381	1101.27	O-Ring	6				
1382	1101.29	O-Ring	7				
1386	1101.33	O-Ring	1				
1389	1101.41	O-Ring	1				
1407	1101.62	O-Ring	1				

* Parts included in Diaphragm Repair Kit - Part #8700.26
 Diaphragm Repair Kit also available in BUNA-N - Part #8700.25
 ** Parts for KAPPA-35/TS & KAPPA-55/TS only.
 *** Parts for KAPPA-35 only.
 † For use with new style heads and pulsation dampener purchased after 12-1-98.